

Managing and supporting Pandemic Response: Information and Communication Threats, Risks and Mitigating controls

Contact: Tyson Macaulay, Bell Canada
Tyson.macaulay@bell.ca
613 781 0822

Methodology

- Client-driven
- Internal consultations
 - telephony / connectivity / wireless, call-centres, security (corporate and customer-facing)
- External consultations (international)
 - Industry: hospitals, police (fed/prov/muni), paramedics, EMS, banking, energy, water,
 - Academia
 - Government: federal, prov, municipal

Scenario

- Flu-like virus with infection rate of 20 to 40% of population over 2 years
- 0.1% hospitalization rate
- 6% mortality after hospitalization
- WHO stage 6 declared
- Social-distancing recommendations from government

ICT under normal operating conditions

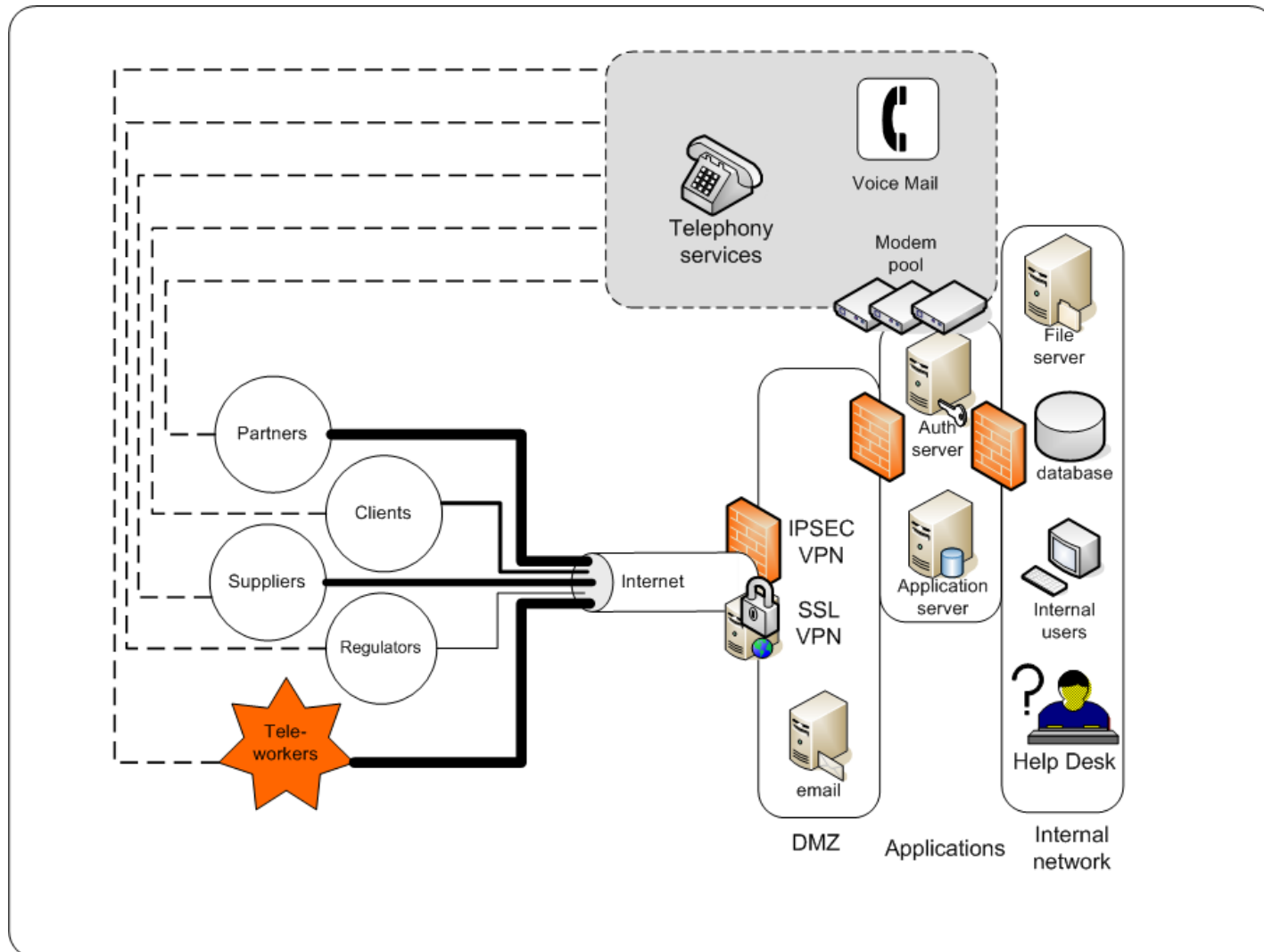

Stage 1 impact – Help Desk and Vmail degradation

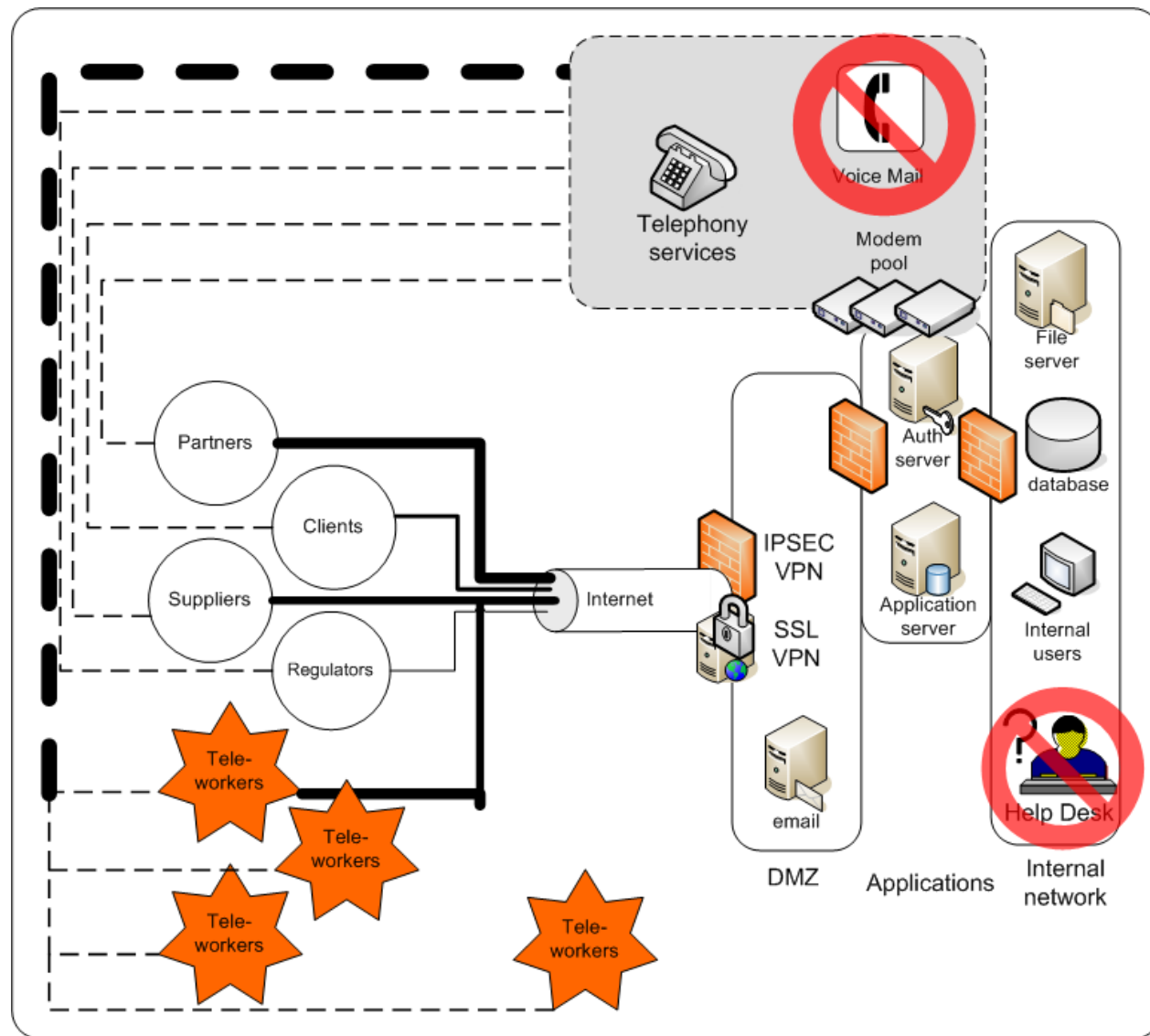

Stage 2 impact – Internet degradation

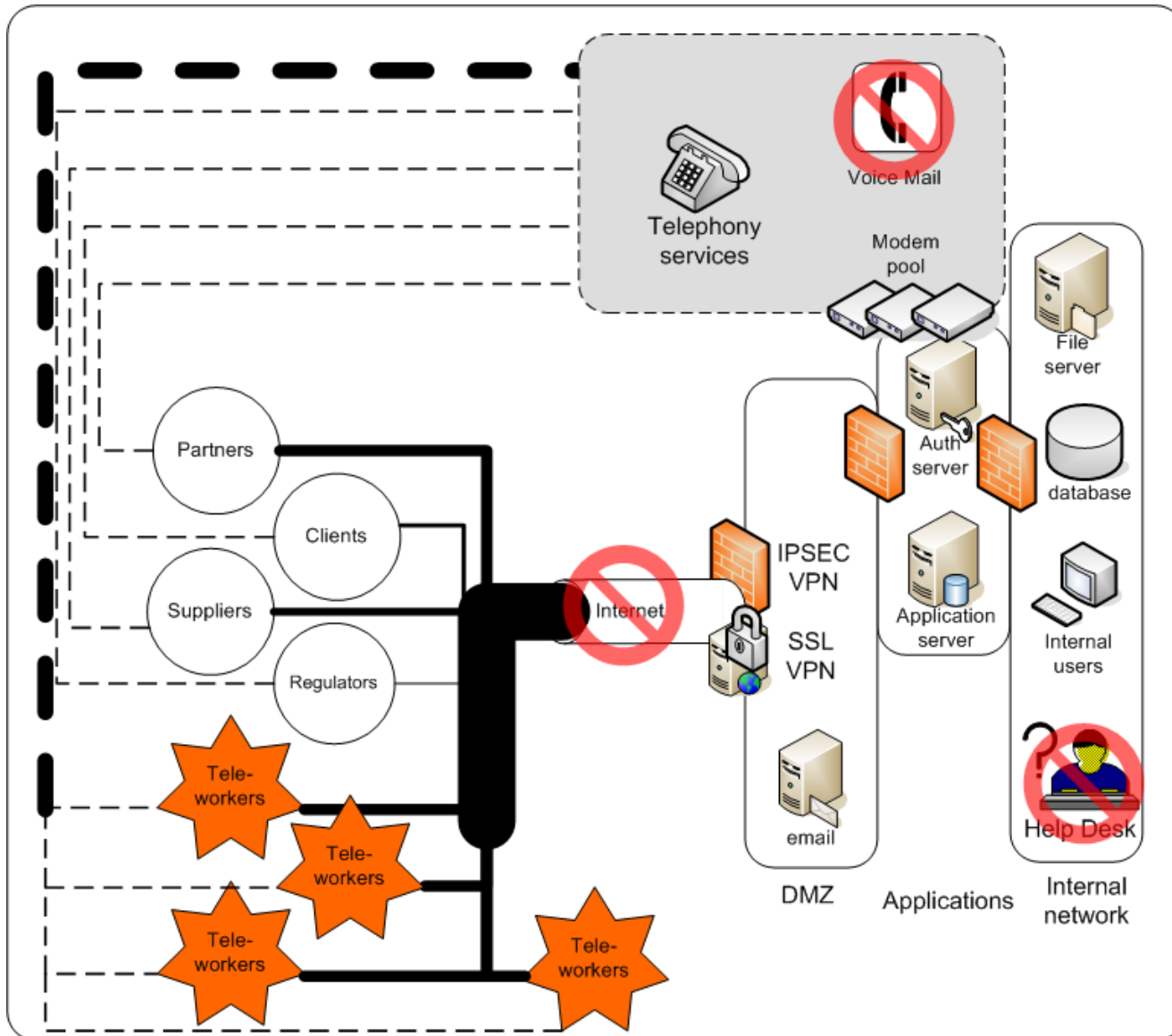

Stage 3 impact – Telephony degradation

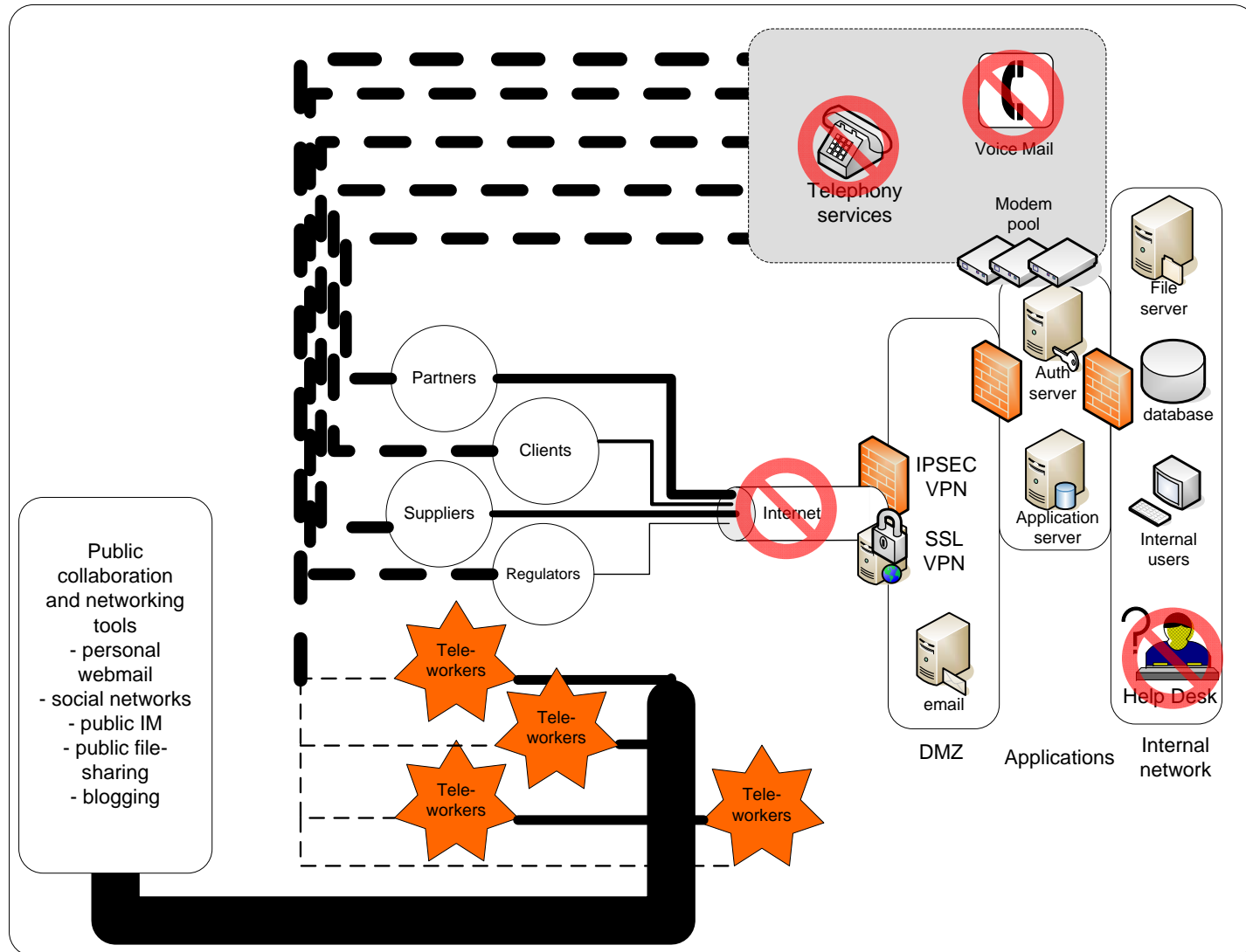

Stage 4 impact – Information Asset compromise

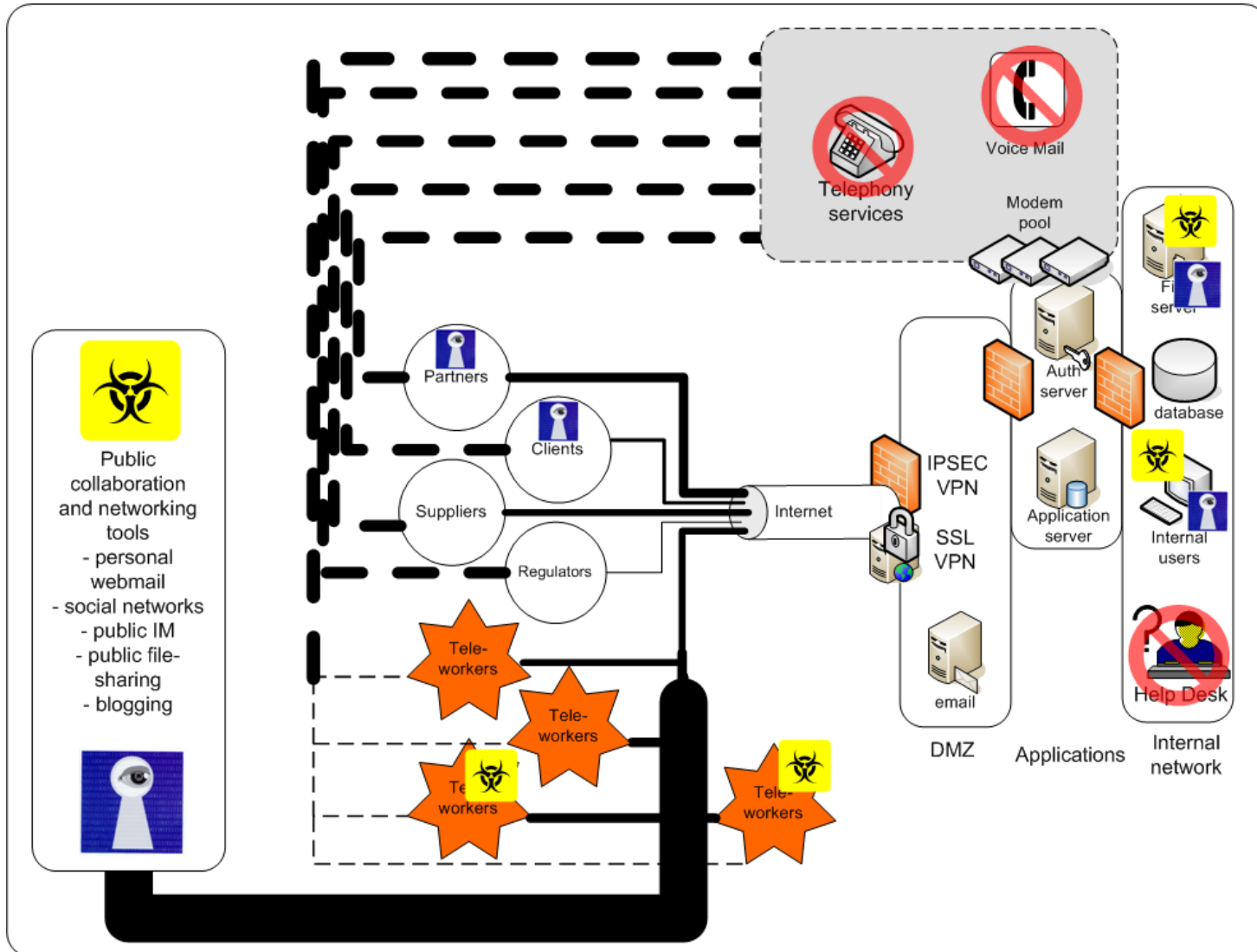

Pandemic Response Mitigating Controls

Stage 1 impact – Controls

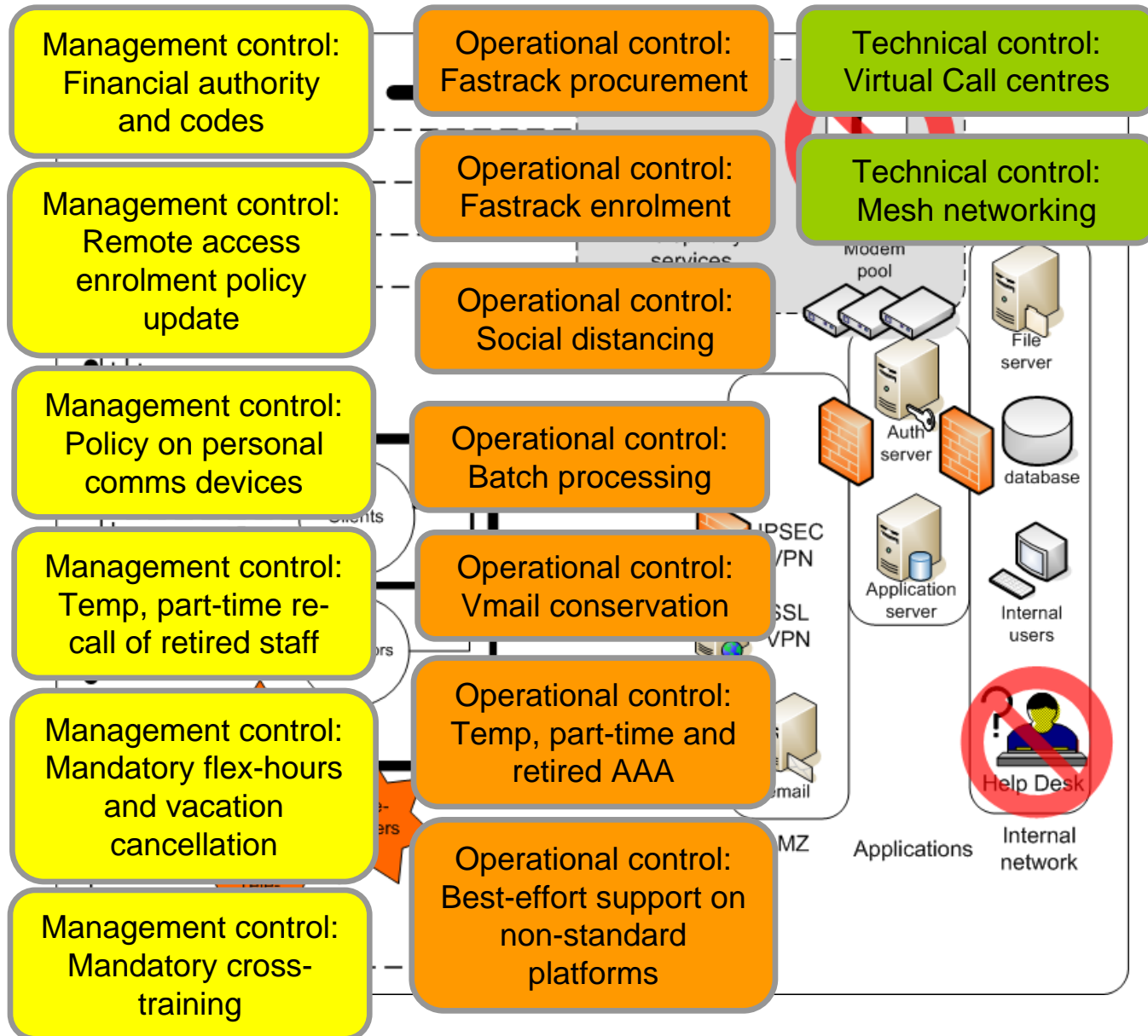

Stage 2 impact – Controls

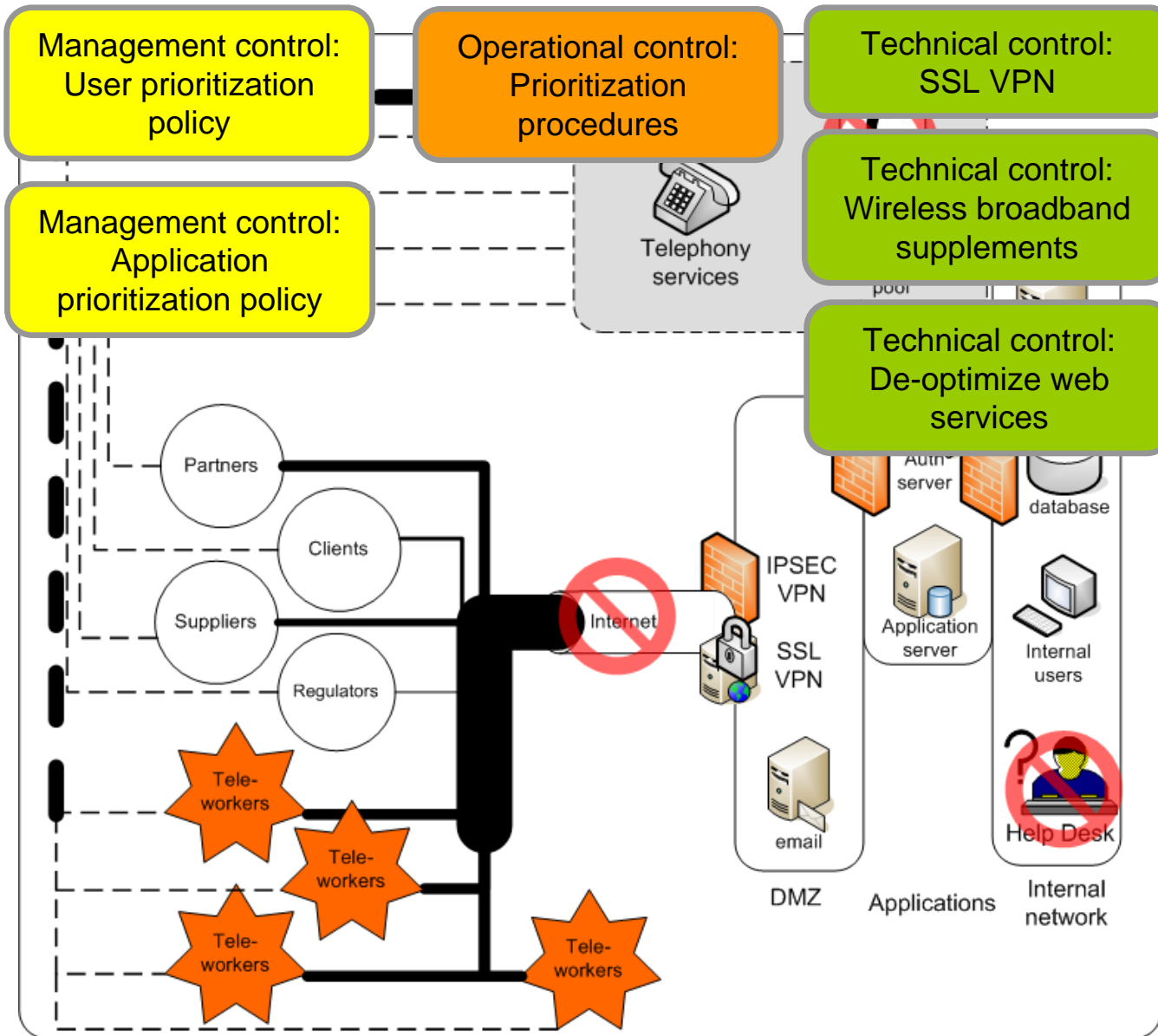

Stage 3 impact – Controls

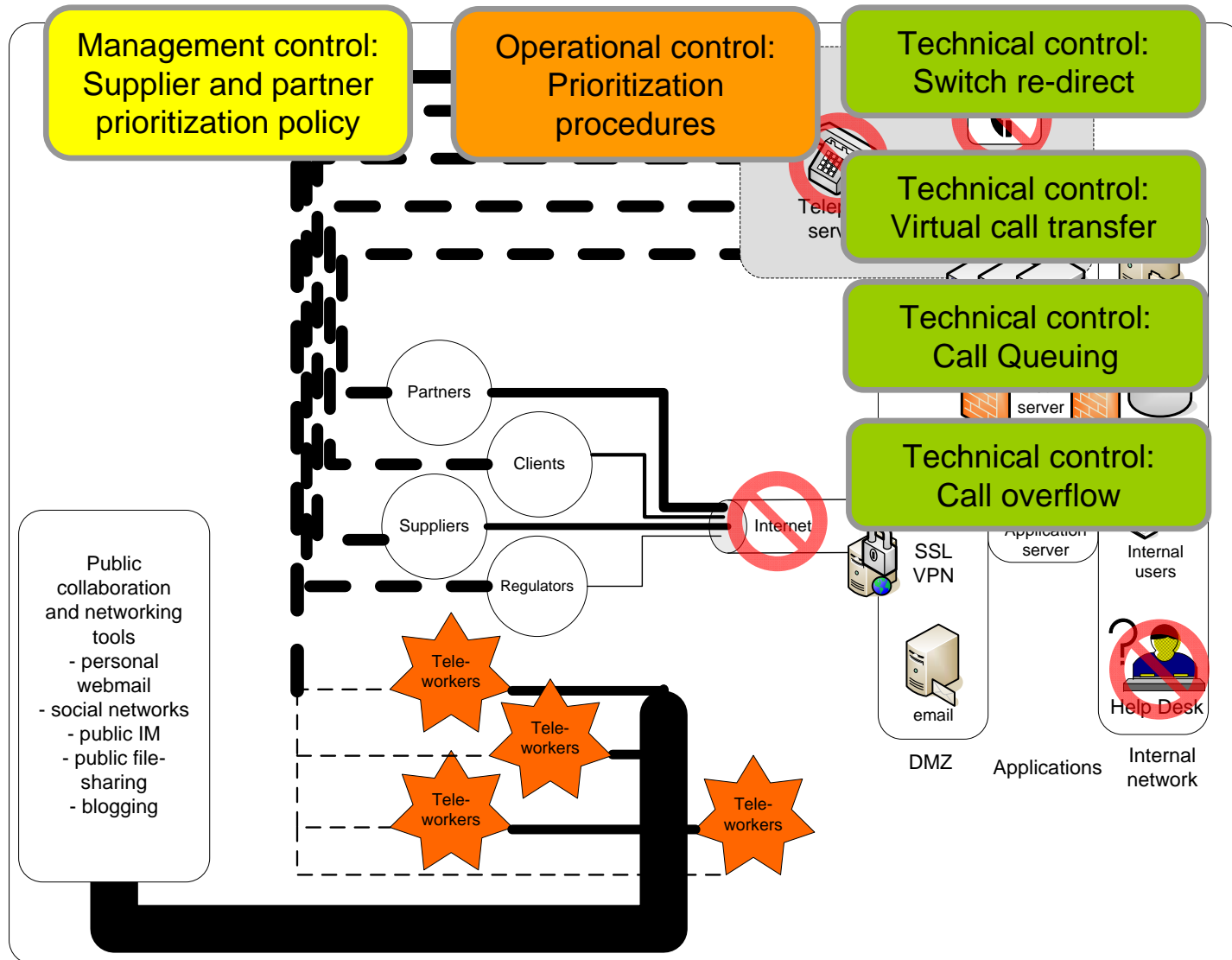

Stage 4 impact – Controls

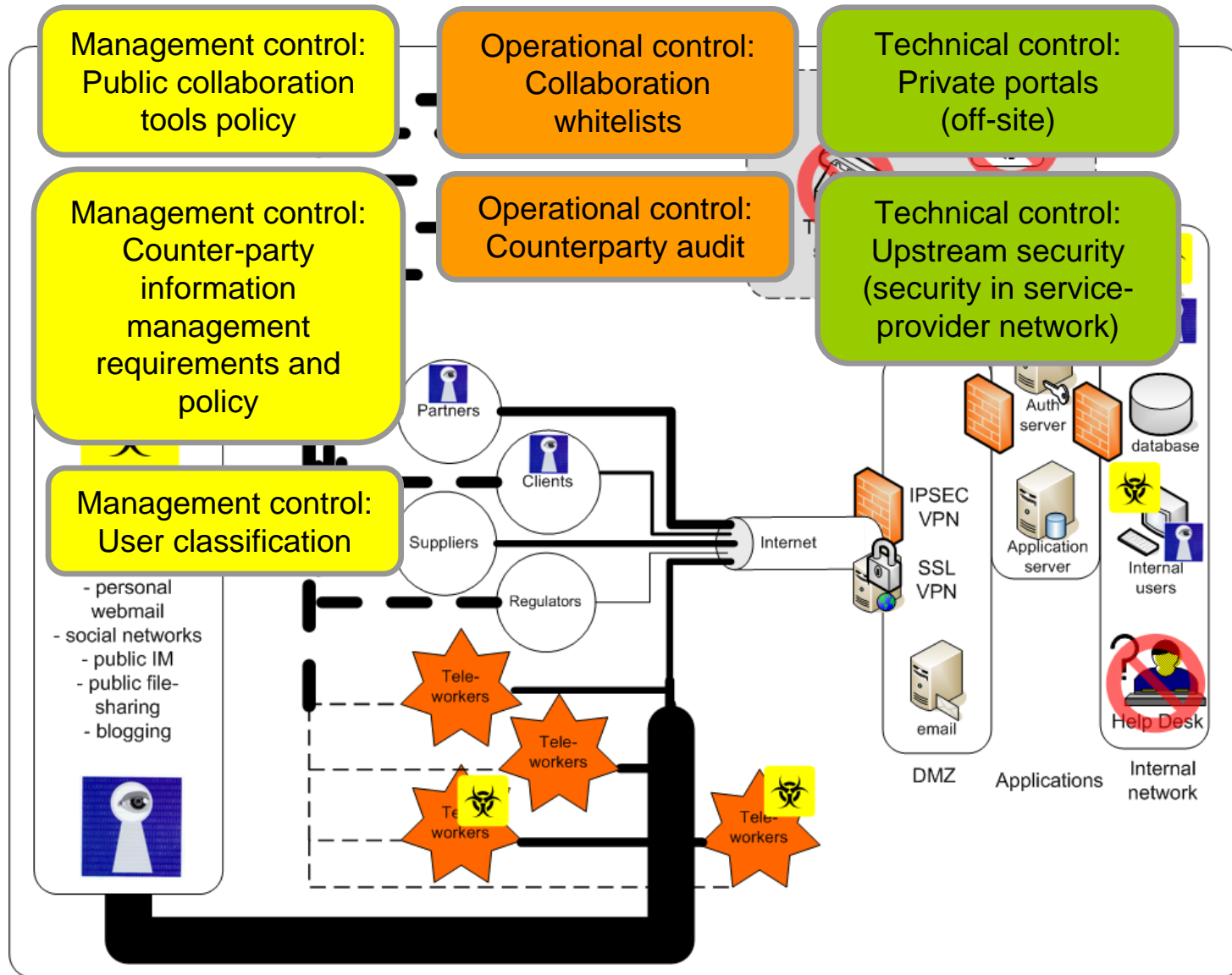

BeH